

The garden:

# The three cent row maker

**Eliminate back breaking work & save time with this simple device.**

BY DENNIS "BONES" EVERS  
 COLORADO  
 ZONE 4

One of the great things about living in the country is having a garden. Nothing beats eating a tomato right off the vine, however prepping the garden is another story. After dumping over a ton of well seasoned goat, rabbit, llama and donkey poop into it and tilling it thoroughly four times, the task of making rows would normally be a horribly tedious one, and the wavy results from a hard day's work used to look like I'd been drinking on the job. It only took one season, years ago, before I decided that the Recycle Ranch needed dirt cheap,

easy to build, easier to use row makers. After a full 30 minutes of work, I came up with a device that not only works great, but lasts as well. This is its 10th year in service and it has another hundred left.

The row maker is simple to build out of steel, but a scrap wood one could be built if you didn't have a welder and made it beefy enough.

The beauty of this device is its simplicity. Constructed from an old piece of tubing, some angle iron, a discarded water pipe and two junk steel plates, it has worked flawlessly without as much as a broken weld.

Attached to the ATV with an old 1/2" bolt, I must emphatically advise how dangerous and stupid it is to stand on the row maker, and never,



For nice straight garden rows, you can't beat this homemade row marker (see plan on next page). Above: Apparently no one above wants to face the camera, and we don't blame them. Rigging a weight to the bar would be much safer.

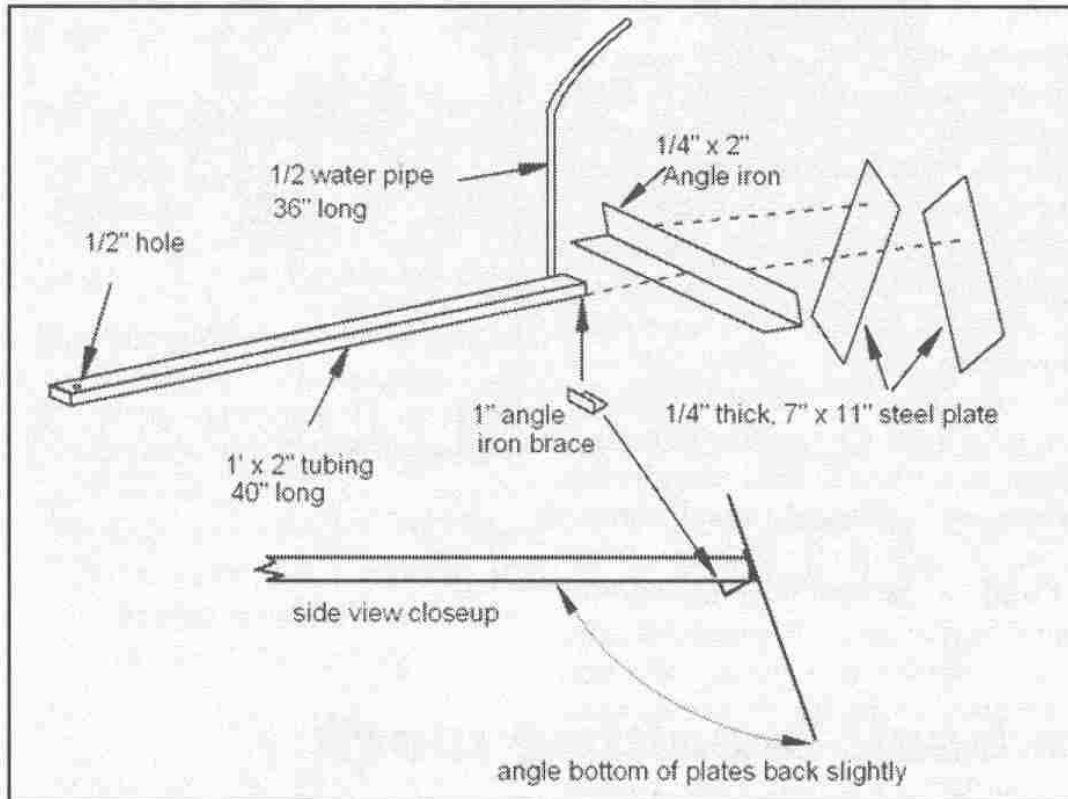

ever do this at home, but it works great for us. In first gear at just a crawl, the unit makes perfectly straight rows and will do a huge garden in under an hour.

Getting ready to make the last row to the right, the rest of the garden is ready to plant. Total cost, around

three cents for electricity to run the welder.

If you have materials that are even close, they should work fine.

Now when it comes time to prep the garden and make the rows, I don't break into a sweat, I simply whip out the old trusty three center and get to work.

